

BROOKLYN SHARED PATHWAY & BOARDWALK

SEYMOURS CREEK TO KANGAROO POINT

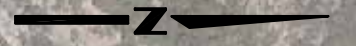

PRELIMINARY
NOT FOR CONSTRUCTION
ISSUED FOR INFORMATION ONLY



PRELIMINARY
NOT FOR CONSTRUCTION
ISSUED FOR INFORMATION ONLY

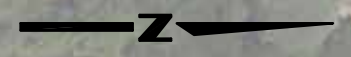

CONTINUED FROM SHEET No.1

CONTINUED ON SHEET No.3

PRELIMINARY
NOT FOR CONSTRUCTION
ISSUED FOR INFORMATION ONLY

Design and Construction Branch
Hornsby Shire Council
296 Pacific Highway, Hornsby
PO Box 37, Hornsby NSW 1630

Telephone 9847 6666
8.30am-5pm Monday to Friday
hornsby.nsw.gov.au

**BROOKLYN SHARED PATHWAY & BOARDWALK
SEYMOURS CREEK TO KANGAROO POINT**
CONCEPT PLAN
SHEET 2 OF 3





PRELIMINARY
NOT FOR CONSTRUCTION
ISSUED FOR INFORMATION ONLY

GENERAL NOTES:

- ALL TIMBER TO BE CCA TEATED HARDWOOD HAVING A DURABUILD CLASS OF 2 FOR A HAZARD LEVEL OF 6 FOR POLES. ALL OTHER TIMBERS TO BE H4 IN ACCORDANCE WITH AS1720 & AS1604.
- ALL BOLTS & NAILS TO BE HOT DIPPED GALVANISED.
- ALL VISIBLE BOLTS & NAILS TO BE COUNTER SUNK.
- DRILLING OF HOLES FOR TIMBER POSTS & CONCRETE FOOTINGS TO BE UNDERTAKEN DURING LOW TIDE TO MINIMISE DISTURBANCE OF EXISTING EARTH.
- CONCRETE PADS/FOOTINGS ARE TO BE PRECAST & NOT POURED INTO HOLES.
- SPILL MATERIAL FROM FOOTING HOLES TO BE PLACED ON PLASTIC GROUND SHEETS & REMOVED FROM CONSTRUCTION SITE & DISPOSED OF APPROPRIATELY.
- BACKFILL POST HOLES WITH WELL CONSOLIDATED CLEAN SAND.
- WHERE FINISHED BOARDWALK LEVEL IS GREATER THAN 0.9m ABOVE GROUND LEVEL TIMBER HANDRAILS ARE TO BE PROVIDED.
- ALL TIMBER OFF-CUTS TO BE REMOVED FROM CONSTRUCTION SITE & DISPOSED OF APPROPRIATELY.

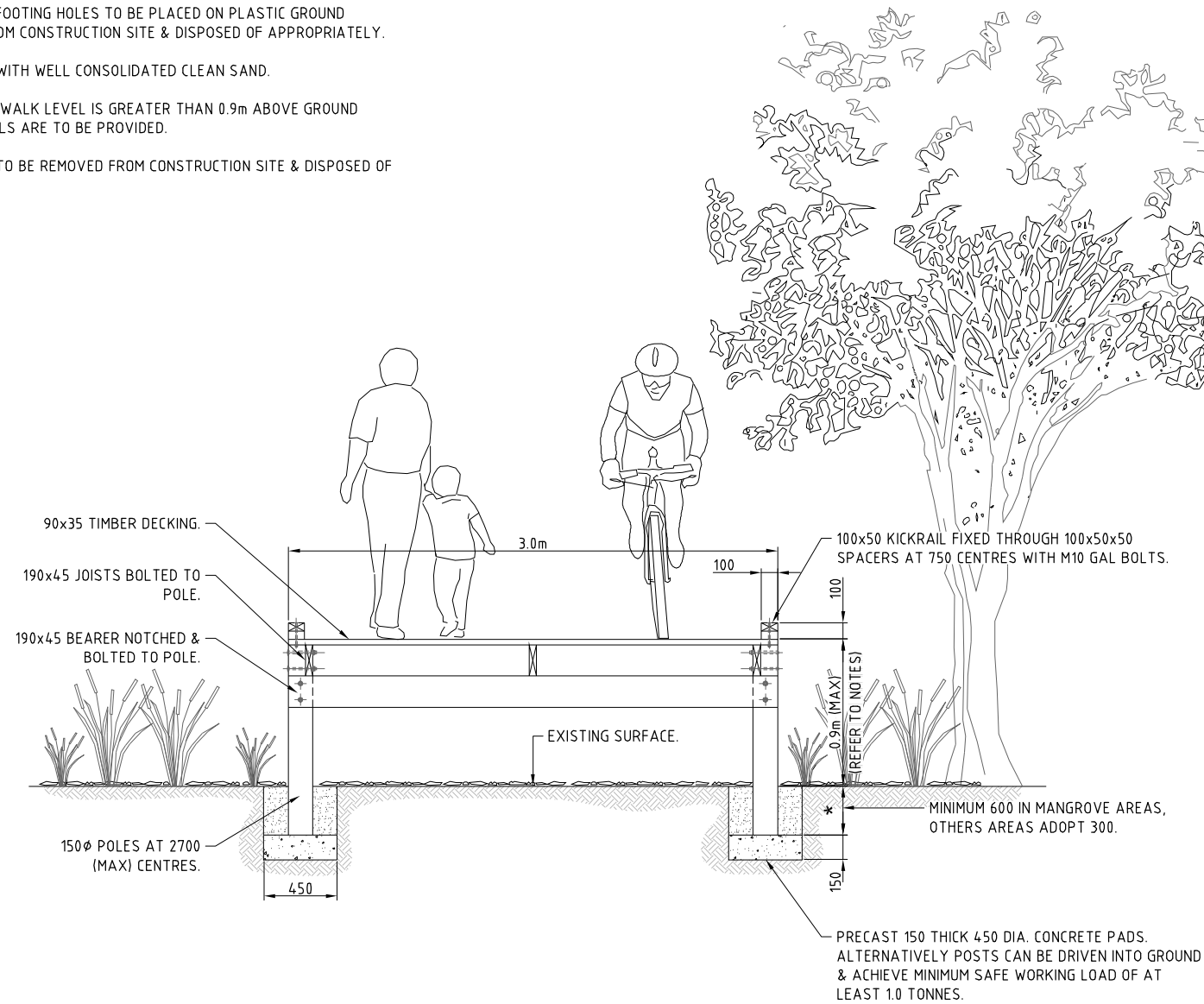

TYPICAL SECTION - TIMBER BOARDWALK
NOT TO SCALE

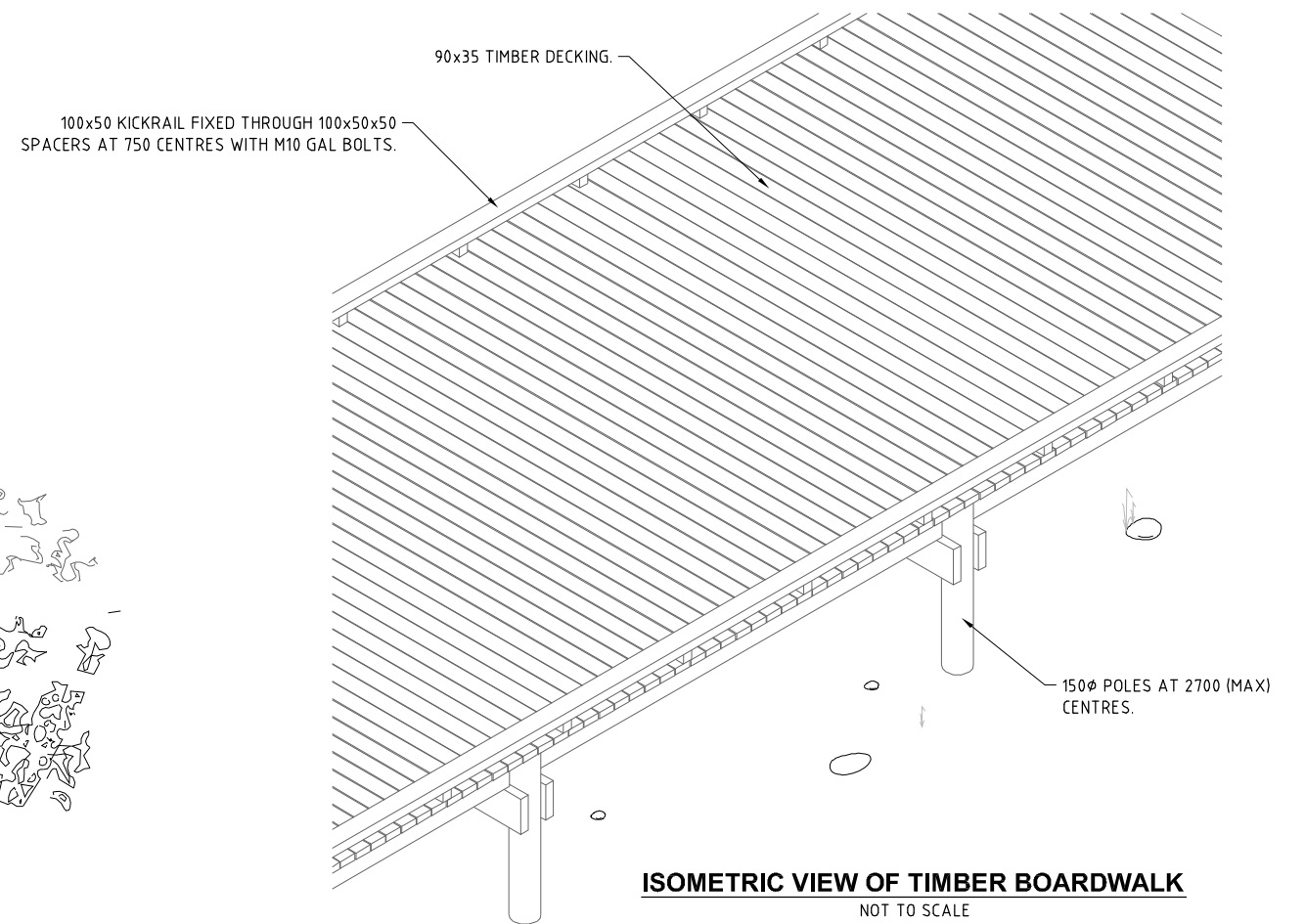

ISOMETRIC VIEW OF TIMBER BOARDWALK
NOT TO SCALE

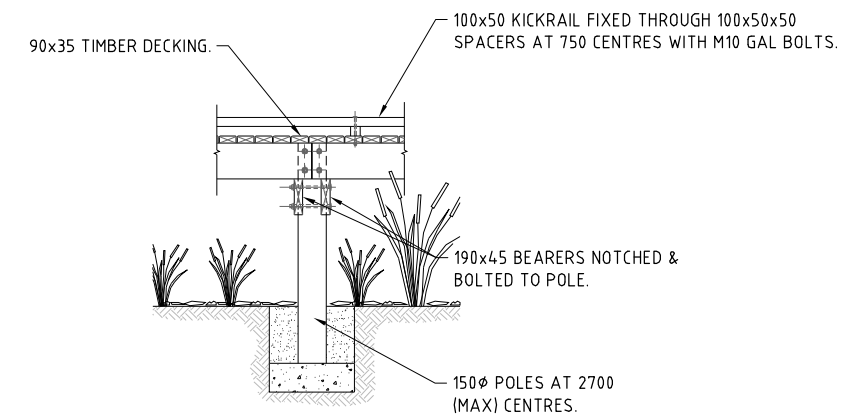

ELEVATION OF TIMBER BOARDWALK
NOT TO SCALE

PRELIMINARY
NOT FOR CONSTRUCTION
ISSUED FOR INFORMATION ONLY

GENERAL NOTES:

- ALL MATERIALS & CONSTRUCTION TO BE IN ACCORDANCE WITH AS3600, AS3610 & AS4671.
- ALL CONCRETE QUALITY TO AS1379.
- CONCRETE TO BE INTEGRALLY COLOURED WITH CONCRETE COLOURED SYSTEMS PRODUCTS OR EQUIVALENT. (COLOUR TO MATCH KANGAROO POINT WORKS).
- ANY EXCAVATED MATERIAL FROM SITE TO BE PLACED ON PLASTIC GROUND SHEETS & REMOVED FROM CONSTRUCTION SITE & DISPOSED OF APPROPRIATELY.
- BACKFILL ONLY WITH WELL CONSOLIDATED CLEAN MATERIAL.
- SIGNAGE & LINE MARKING TO BE INSTALLED IN ACCORDANCE WITH AS174.2.9 & NSW BICYCLE GUIDELINES.
- NO WORK SHALL BE UNDERTAKEN UNTIL APPROPRIATE EROSION & SEDIMENT CONTROL MEASURES ARE IN PLACE & APPROVED BY THE PROJECT MANAGER.

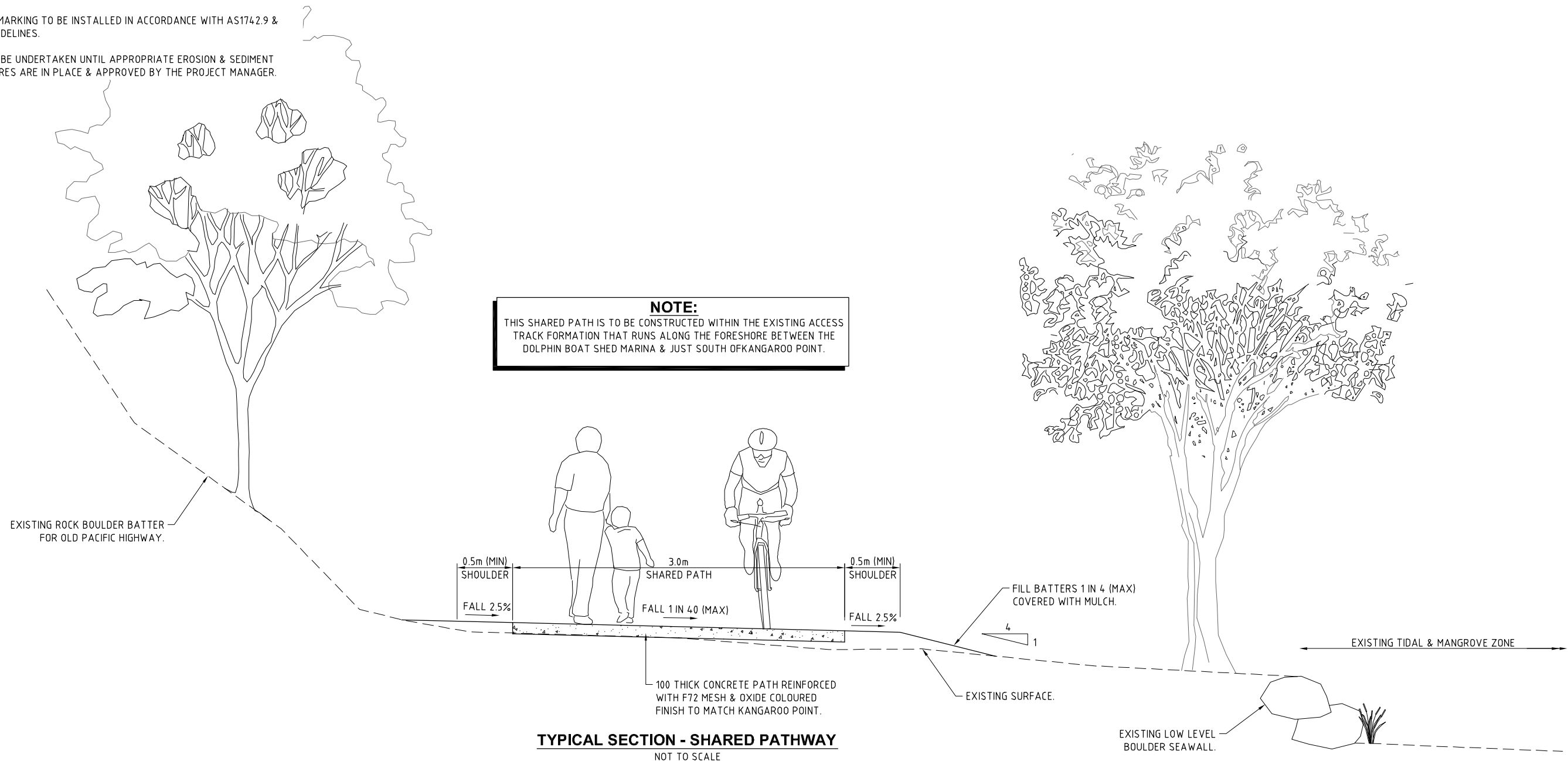

PRELIMINARY
NOT FOR CONSTRUCTION
ISSUED FOR INFORMATION ONLY



PHOTO 1
(LOOKING NORTH TOWARDS KANGAROO POINT)



PHOTO 2
(LOOKING SOUTH)

PRELIMINARY
NOT FOR CONSTRUCTION
ISSUED FOR INFORMATION ONLY